

**STREETS AHEAD**

**DuraFlex**<sup>®</sup>

AUSTRALASIAN  
**Waste &  
Recycling Expo**



Best value

Optimal performance

Innovative design for maximum strength

Introducing

## **DuraFlex Bins and Lids**



+44 (0)1246 853 696 | [enq@duraflexlids.co.uk](mailto:enq@duraflexlids.co.uk) | [www.duraflexlids.co.uk](http://www.duraflexlids.co.uk)

**Container Components Europe Ltd.**

Moore Close, Holmewood Industrial Park  
Chesterfield, S42 5UX, United Kingdom

**DuraFlex**<sup>®</sup>

We've got it **covered**



## Container Components Europe Limited pioneered the introduction of plastic lids in 1994.

We now manufacture over a million lids each year at plants in Atlanta, GA and Jonesboro, AR, in the USA and Chesterfield in the UK and have expanded distribution globally now reaching all 5 continents. Originally replacing metal lids, a significant cause of serious injuries and even fatalities, we have played a key role in making the waste industry a safer working environment.

Uniquely focused on the supply of plastic lids for the global waste market, CONTAINER COMPONENTS EUROPE LIMITED have made major investments in the latest design technology, research and development, personnel training and in-house

manufacturing capabilities to meet the challenges of the industry both now and in the future. Worldwide, the brand name DuraFlex® is synonymous with quality and innovation.

We deliver to virtually all the world class container builders, plastic injection moulders, as well as the top waste contractors, repairers and local authorities.

We are excited to announce our new addition, the DuraFlex EN840 approved metal bin and with our wide range of accessories and other lid options, DuraFlex now provide complete solutions for all environments.

### Frontlift bins built by our main partner in Australia, Toro Waste Equipment



- 3.0 cu.m flat-top bin fitted with DuraFlex FN3659 lids and front grill for visibility of contents



- 4.5 cu.m galvanised sloped-top bin fitted with DuraFlex FN3659 lids and lid stays



## DURAFLEX - 25 YEARS OF INDUSTRY KNOWLEDGE



*Underside of DuraFlex 1100 Litre Bin showing reinforced base and castor mounting brackets*



*DuraFlex 660 Litre Bin with MLO660RM recycling lid*



*DuraFlex 1100 Litre Bin with MM4937RM lid-in-lid*

## Features

### Highest Specification as standard

- Certified EN840 compliant by SKZ-Testing GmbH
- Hot dip galvanised to EN ISO 1461
- 1.5mm body with fully internally welded seams to eliminate water ingress
- 1.8mm base with strengthening ribs to optimise life (1100litre model)
- Strongest comb lifting bar on the market with 7 gussets
- Skillfully designed castor mounting brackets to extend castor life (Patent Pending)

### Durability

The Bin designed to last 15 years - maintenance package provided from cradle to grave including replacement lids and

pressed steel bases. A plastic bin becomes a throwaway product once the body, comb bar or hinge brackets fail. A 'bargain' purchase is a false economy.

### Flexibility

We are able to provide the Bin in whichever format you choose. If customisation is required, we can deliver it fully welded in raw steel for later galvanising in situ. In case utilisation of local labour is perceived as a benefit, the Bin lends itself readily to flat-packing.

### Options

- DIN trunnions
- An unrivalled choice of lid models, both standard and recycling
- A wide range of locking solutions

**We've got it covered.**



The renowned brand of Container Components Europe Ltd.

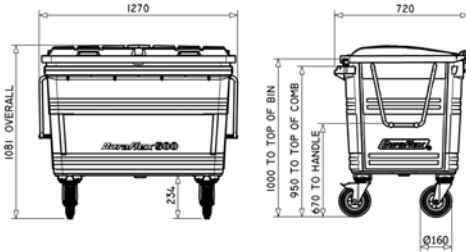

DURAFLEX 500 LITRE CONTAINER

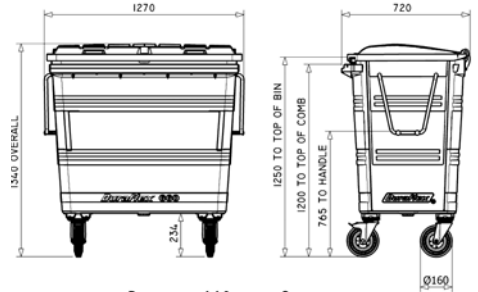

DURAFLEX 660 LITRE CONTAINER

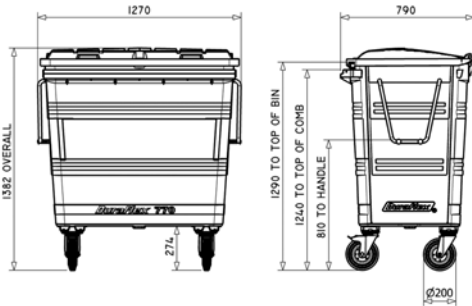

DURAFLEX 770 LITRE CONTAINER

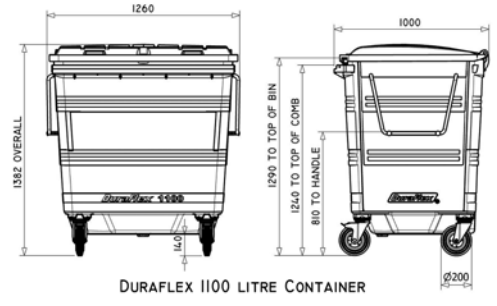

DURAFLEX 1100 LITRE CONTAINER

## 25 years of industry knowledge

+44 (0)1246 853 696

[info@duraflexlids.co.uk](mailto:info@duraflexlids.co.uk)

[www.duraflexlids.co.uk](http://www.duraflexlids.co.uk)

Container Components Europe  
Moore Close, Holmewood Industrial Park  
Chesterfield, Derbyshire, S42 5UX, UK



Cert No. 8998  
ISO 14001



Cert No. 8998  
ISO 9001